



Series
NSX

SIZE 5 COAXIAL PIN CONTACT ENVIRONMENTAL
FOR RG178 AND KX21 CABLES

Issue:
22 OCT 98

Page
1 / 2

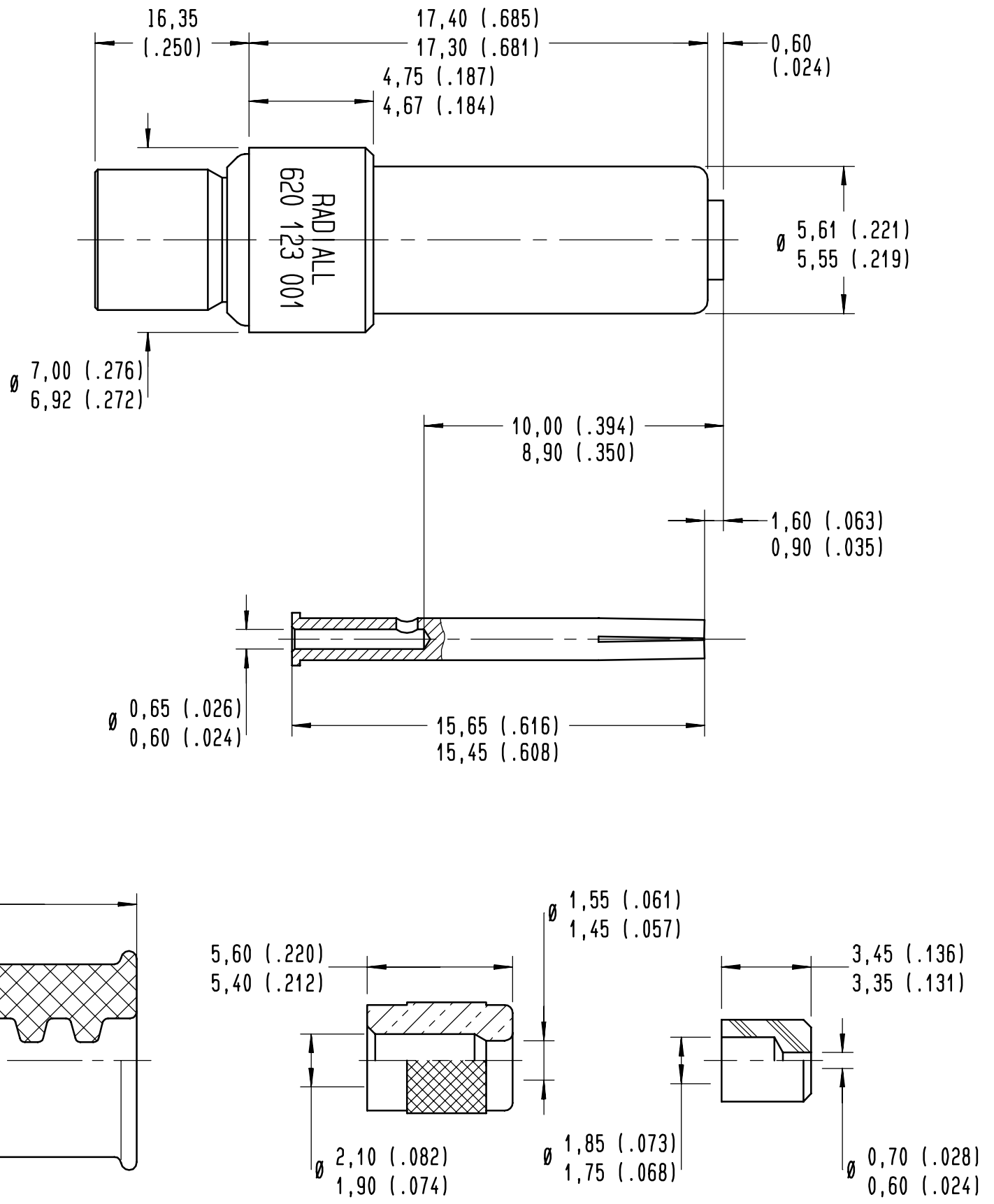

This information is given as an indication. In the continual goal to improve our products, we reserve the right to make any modifications judged necessary.

CREATION
PEN: M980009365A
NOM: VALGRESY
DATE: 22 OCT 98
APPR.: .

Issue	Revisions	Name	Approved



MATERIAL:

OUTER CONTACT: ANNEAL BRASS
CENTER CONTACT: BERYLLIUM COPPER PER ASTM-B-196
INSULATOR: PTFE
FERRULE: ANNEAL BRASS
SEALING BOOT: FLUOROSILICONE ELASTOMER PER MIL-R-25988 OR PER ZZ-R-765

FINISH (ALL METAL PARTS)

PLATING 50 MICROINCHES OF GOLD PER MIL-G-45204 TYPE I OR II GRADE C OR D
CLASS 1 OVER NICKEL PER QQ-N-290

DESIGN REQUIREMENTS

TEMPERATURE RANGE: -65° C TO +165° C
IMPEDANCE: 50 OHMS NOMINAL
RATED VOLTAGE: 325 V RMS AT SEA LEVEL
VSWR: 1.10:1 FREQUENCY RANGE : 0 - 300 MHZ
VSWR: 1.30:1 FREQUENCY RANGE : 300 - 500 MHZ
FREQUENCY RANGE: 0 - 500 MHZ
DIELECTRIC WITHSTANDING VOLTAGE: 750 VRMS AT SEA LEVEL

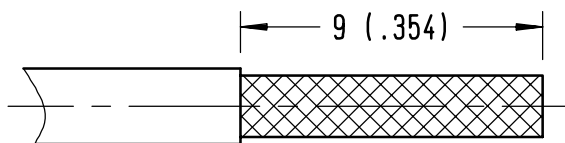

SLIDE THE SEALING BOOT OVER THE CABLE

STRIP THE BRAID AT DIMENSION SHOWN

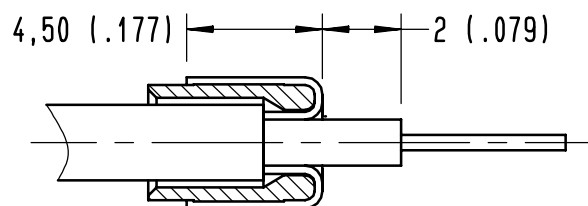

SLIDE THE FERRULE OVER THE BRAID UNTILL IT BUTTS
AGAINST CABLE JACKET
FOLD BACK BRAID OVER FERRULE
CUT BRAIDS AT DIMENSION SHOWN
STRIP CENTER CONDUCTOR AT DIMENSION SHOWN

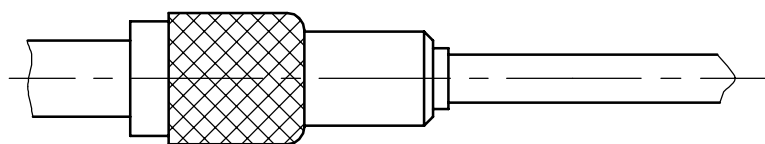

SLIDE DIELECTRIC SLEEVE AND CENTER CONTACT OVER
CENTER CONDUCTOR
CRIMP CENTER CONTACT USING:
CRIMPING TOOL : M22520/2-01 RADIAL 282281
SELECTOR : 6
POSITIONER : K345 RADIAL 282550

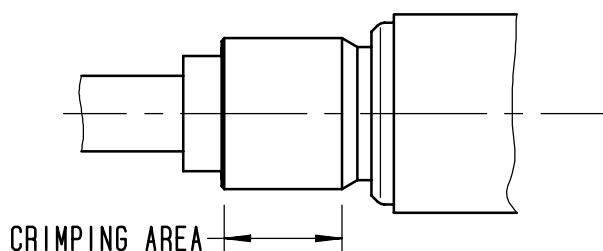

INTRODUCE CENTER CONTACT SUB ASSEMBLY INTO OUTER
CONTACT AND CRIMP USING:
CRIMPING TOOL : M22520/5-01 RADIAL 282293
DIE : M22520/5-05 RADIAL 282246 HEX B 4,5 (.177) /FLATS

EXTRACTION TOOL: M81969/28-01 RADIAL 282946

This information is given as an indication. In the continual goal to improve our products, we reserve the right to make any modifications judged necessary.

4113-9306